

HED TBO-5036BV

Vandal-Proof IR Camera

Feature

- 1/3" SONY CCD
- Hight Resolution: 540TVL
- 2.8/3.6/6/8/12 mm small lens/CS mount lens
- Vandal-Proof



Specifications

Model	HED -5036BV
Pickup device	1/3" SONY CCD
Effective Pixels	NTSC:768(H)*494(V),PAL:752(H)*582(V)
Sync system	Internal
Resolution	540TVL
S/N	More than 48dB
Electronic shutter	NTSC:1/60~1/120,000,PAL:1/50~1/100,000
Flickerless Mode	On/Off
Len	2.8/3.6/6/8/12 mm small lens/CS mount lens
Gamma	0,45
White balance	Auto
AGC Gain Control	ON/OFF
Back Light Comp	Auto
Video Output	1.0Vp-p/75Ohm
Power supply	DC12V±10%
Power consumption	90mA
Operating Temp	-10□ to +50□
Weight(g)	
Dimension	please refer to right figure

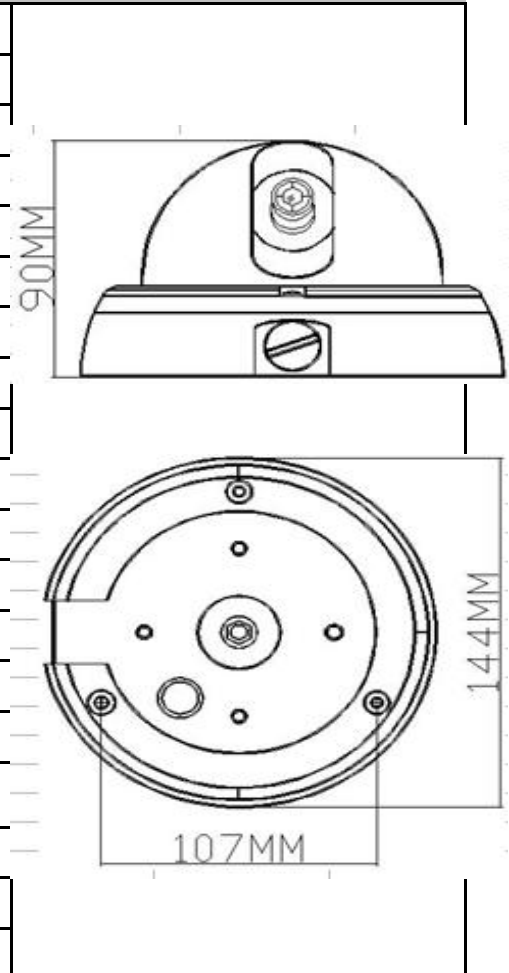

HS

