

TBO-3326C

High resolution with OSD menu Vandal proof IR Box Camera

Feature

- ◆ 1/3" SONY CCD
- ◆ High resolution : 540TVL
- ◆ Built-in multilanguage OSD menu
- ◆ 4 adjustable private zones
- ◆ Motion detect and mirror function
- ◆ Cable inside bracket

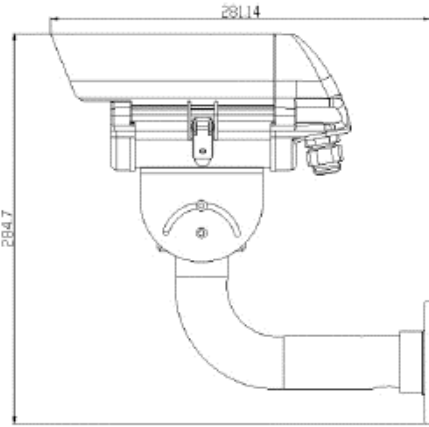
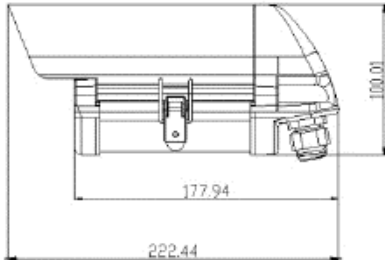
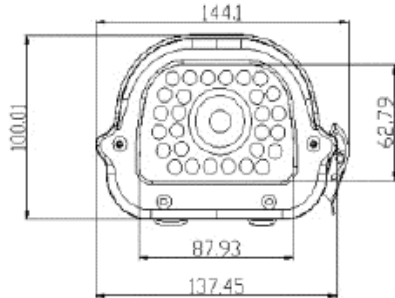

Specifications		Dimension	
Model	TBO-3326C		
Image sensor	1/3" SONY CCD		
Effective Pixels	NTSC:768(H)*494(V),PAL:752(H)*582(V)		
Sync system	Internal		
Resolution	540 TVL		
Min. Illumination	0.2Lux / F1.2, 0Lux (IR on)		
S/N	More than 48dB		
Electronic shutter	NTSC:1/60~1/100,000,PAL:1/50~1/100,000		
Flickerless Mode	On/Off		
Len	4-9mm/6-15mm DC M12 Lens optional		
Gamma	0.45		
White Balance	Auto (ATW,AWB,FIXED,MANUAL)		
AGC Gain Control	High / Low (6dB~40dB)		
Back Light Comp	On / Off (64AREA)		
Motion Detection	On / Off (64AREA)		
Video Output	1.0Vp-p/75Ohm		
Power supply	DC12V±10%		
IR LED distance	IR distance 20~50m		
Power consumption	75mA,325mA(IR ON)		
Operating Temp	-10°C to +50°C		
Weight(g)	1240		